

23

7 ft. x 8 ft. [2134 mm x 2438 mm] 8 ft. x 14 ft. [2438 mm x 4267 mm] 10 ft. x 22 ft. [3048 mm x 6706 mm]

	=	12	36	48
X =		32 in. [813 mm]	24 in. [610 mm]	24 in. [610 mm]

Position bracket edge at pre-marked line
Positionner le rebord du support à la ligne pré-marquée
Coloque el borde de la abrazadera en la línea pre-marcada
 あらかじめついている線に取付金具の端をそろえます

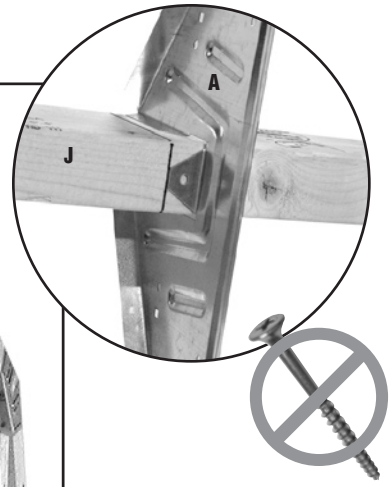
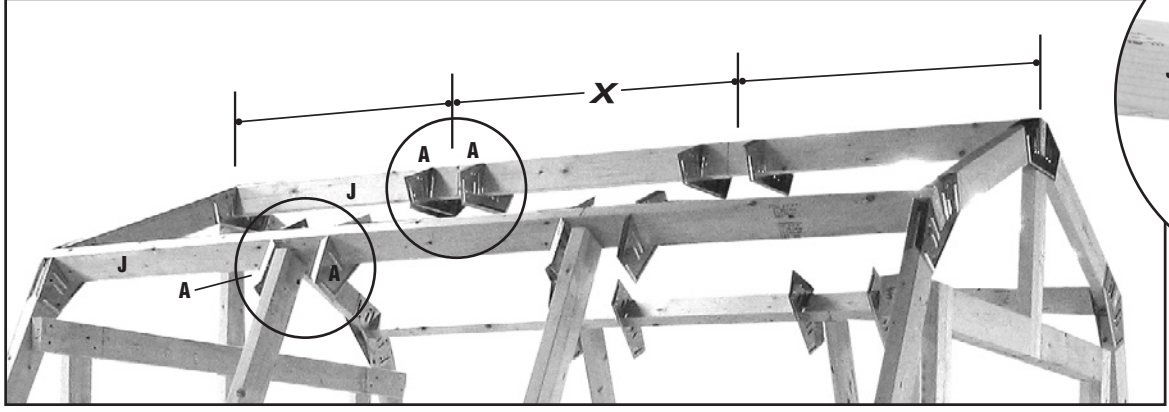

24

1 1/4 in. 32 mm

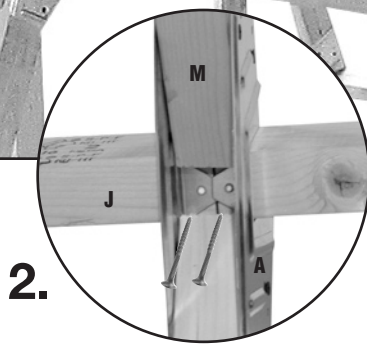
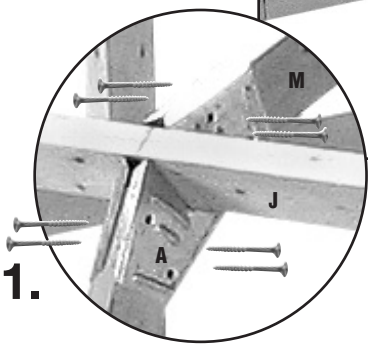
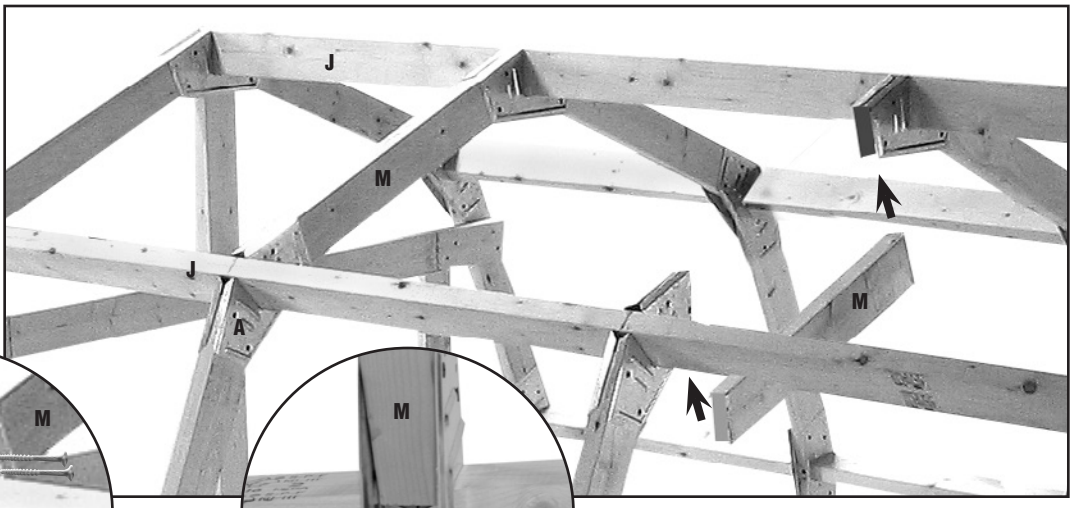

25

2 1/2 in. 64 mm

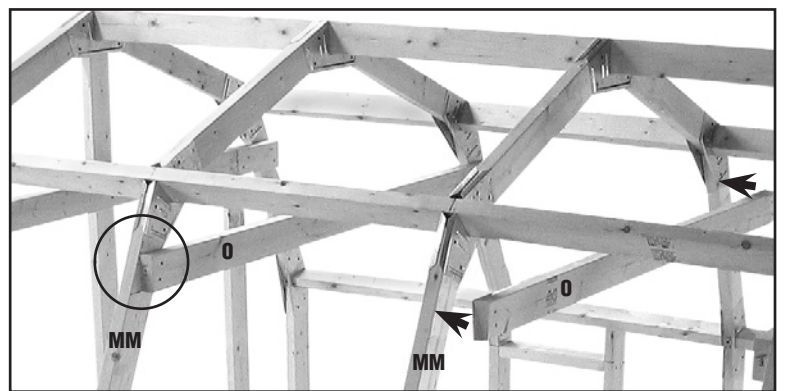
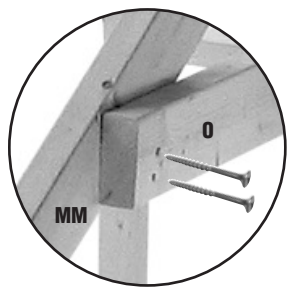

26

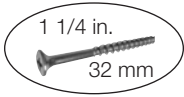

Flush with DOOR JAMB (N)
 A effleurement avec LE MONTANT DE PORTE (N)
 Instale al ras con EL MARCO INTERIOR DE LA PUERTA (N)
 ドア枠にピッタリと揃うようにします (N)

27

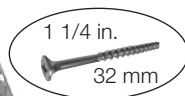
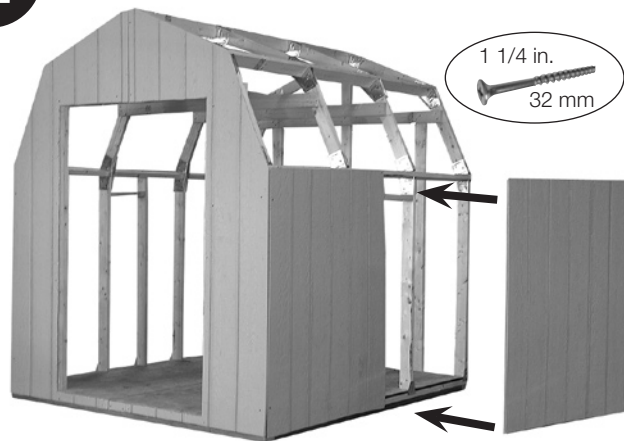

28

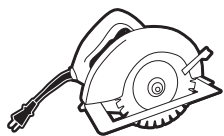

7 ft. x 8 ft.
 [2134 mm x 2438 mm]

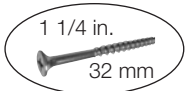
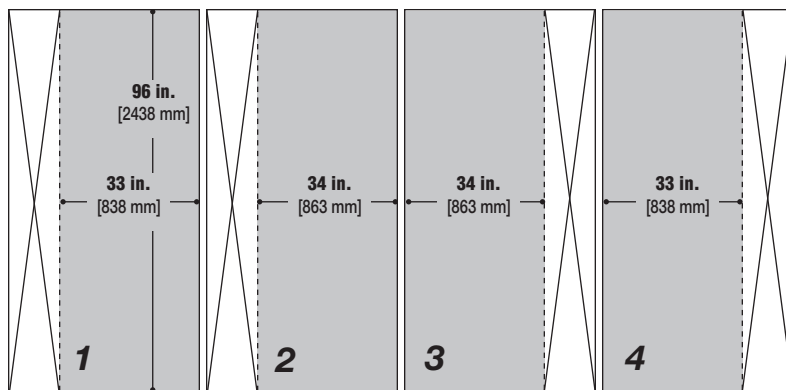

8 ft. x 14 ft.
 [2438 mm x 4267 mm]

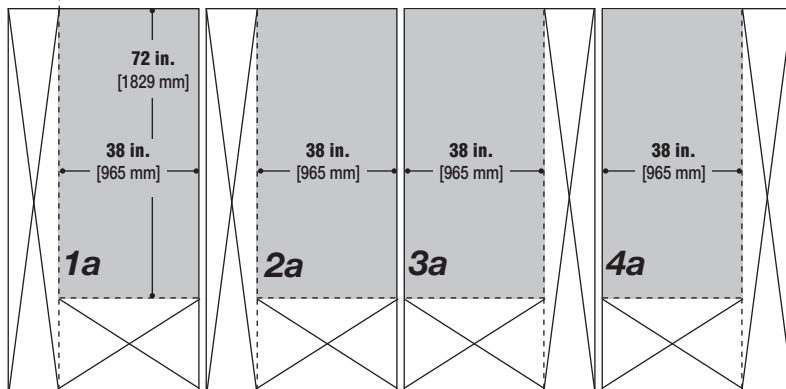
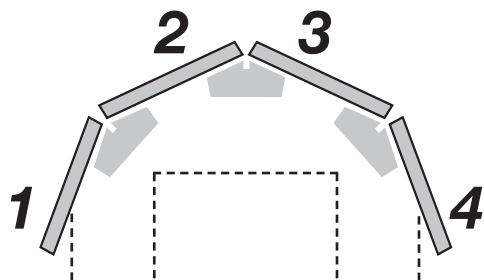
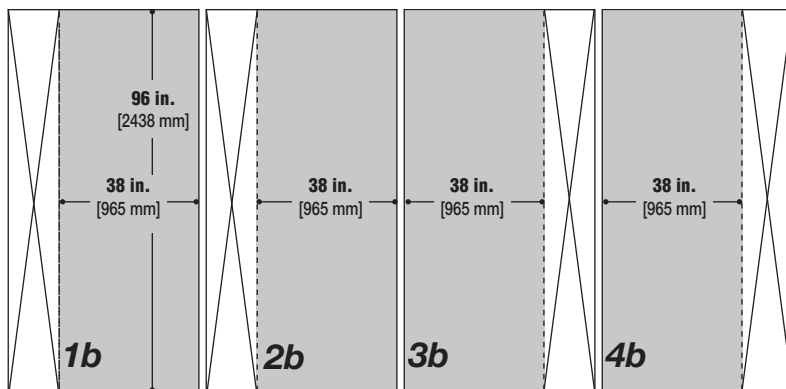

10 ft. x 22 ft.
[3048 mm x 6706 mm]

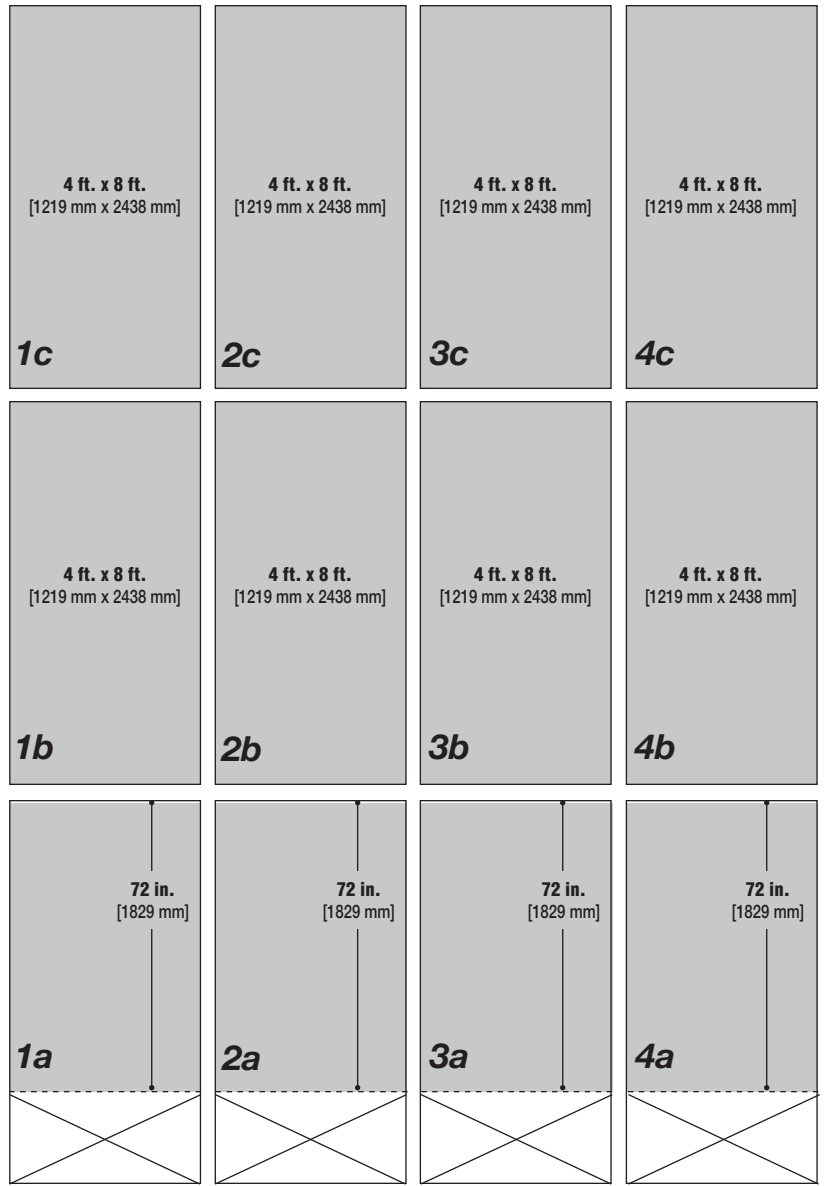
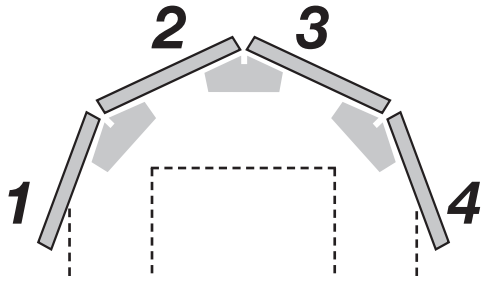

29

 **7 ft. x 8 ft.** [2134 mm x 2438 mm]
  **8 ft. x 14 ft.** [2438 mm x 4267 mm]
  **10 ft. x 22 ft.** [3048 mm x 6706 mm]



14

14

18

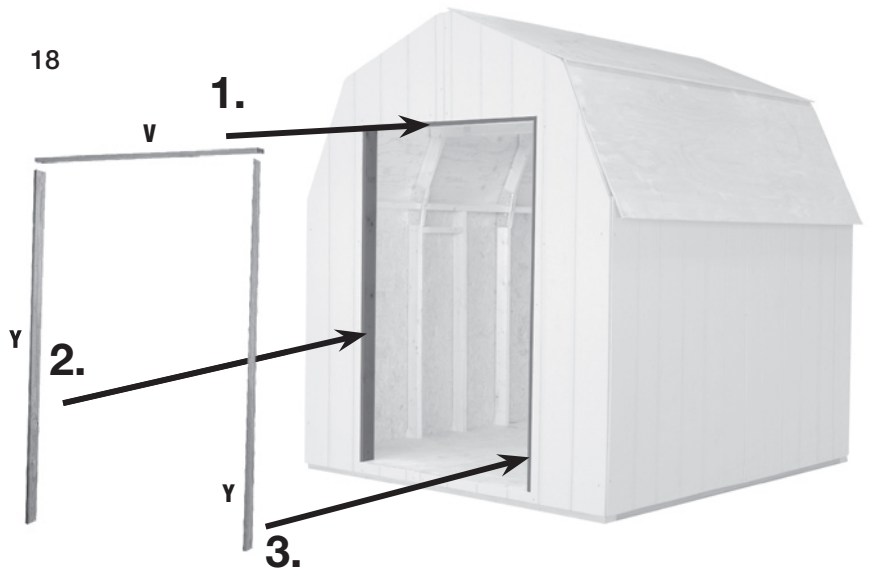

30

7 ft. x 8 ft. [2134 mm x 2438 mm] 8 ft. x 14 ft. [2438 mm x 4267 mm] 10 ft. x 22 ft. [3048 mm x 6706 mm]

DOOR
PORTE
PUERTA
ドア

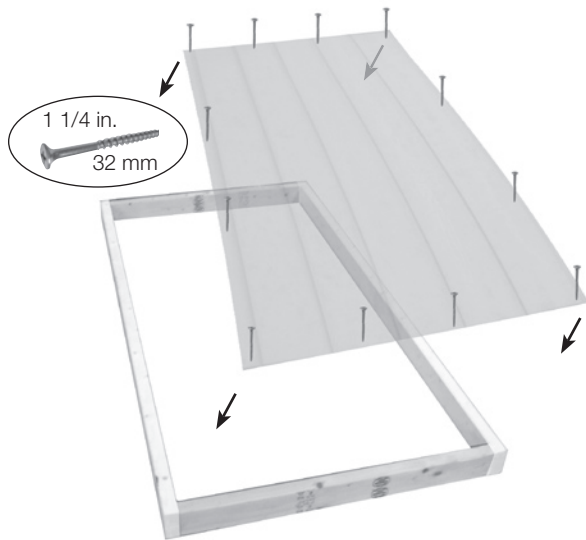
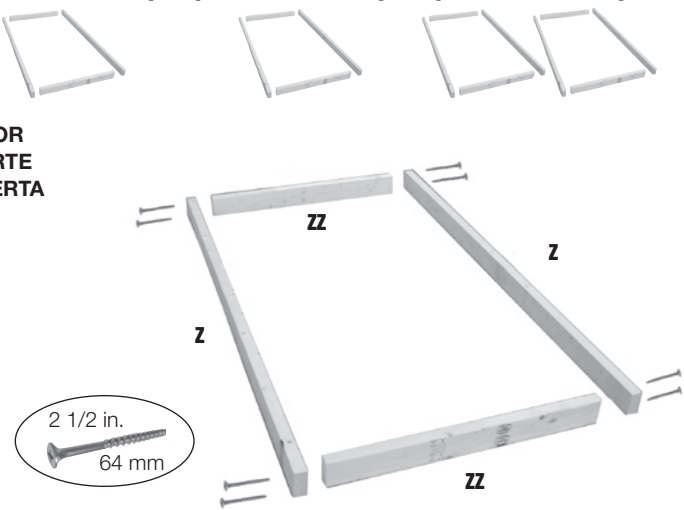

31

Add optional trim, if desired, before hanging door.
Ajouter la garniture optionnelle, si désiré, avant d'accrocher la porte.
Agregue el borde opcional, si lo desea, antes de colgar la puerta.
ドアを取り付ける前に、お好みでオプションのトリム (装飾) を取り付けます

No Trim
Pas de garniture
Sin borde
トリム (装飾) なし



T-hinge recommended
Charnières en T recommandées
Se recomienda bisagra en T
T型ちょうつがいをお勧めします



Optional Trim
Garniture optionnelle
Borde opcional
オプションのトリム



T-hinge recommended
Charnières en T recommandées
Se recomienda bisagra en T
T型ちょうつがいをお勧めします



32

Add roof and trim materials and door hardware if desired.
Ajouter les matériaux de toit et de garniture et la quincaillerie de porte si désiré.
Agregue los materiales para el techo y el borde y la herrajería para puertas si lo desea.
屋根材、トリム (装飾)、およびドア金具をお好みで取り付けます。



www. **2x4 basics** [®] .com

